

CONSTRUCTION NOTES:

A) MATERIALS ARE ALL WELDED 316L STAINLESS STEEL

B) HEAT TRANSFER AREA IS APPROXIMATELY 10.0 SQUARE FEET

C) CONNECTION PORTS ARE 2 OF 1 1/4" NPT AND 2 OF 1 1/2" NPT

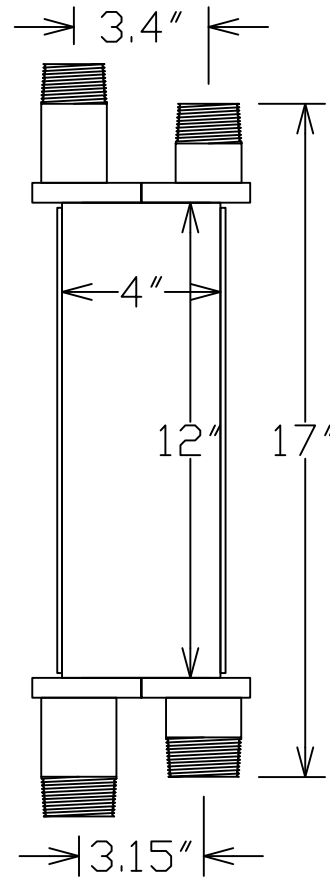
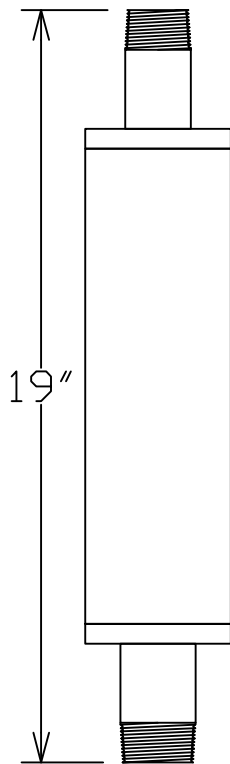
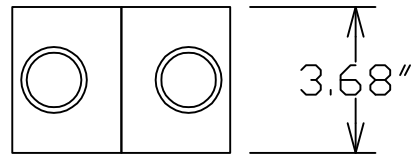

**Carlson**  
HEAT EXCHANGER

MODEL:  
10.0 C

<http://CarlsonHX.com>

Copyright 2011  
Carlson Heat Exchanger